

4AC16L

PRODUCT SPECIFICATIONS

SPLIT AIR CONDITIONER SYSTEM
UP TO 16 SEER

FORM NO. 4AC16L-100 (12/2018)



COMPRESSOR

- High-efficiency scroll compressor
- R410A refrigerant
- Heavy-duty compressor sound blanket for quiet operation
- Internally protected against high temperature motor overload conditions

CABINET

- Full metal louvered construction to protect the coil/ hail protection
- Individual louver panels; 4 screws to remove for ease of coil cleaning and service
- Corner-mounted controls for easy service
- Baked polyester paint finished over galvanized steel for maximum durability
- 45-degree offset valves for easy service

COILS

- Omniguard™ total corrosion protection technology designed coil
- Enhanced tube-and-fin coil design featuring MHT™ Technology
- Lanced fins for maximum heat transfer
- Every coil factory tested for leakproof construction
- Raised coil prevents debris from impeding airflow

COMPONENTS

- Factory installed high pressure switch
- Thread-on pressure switches for simple, quick replacement
- Filter drier shipped loose for installation flexibility
- Fan orifice for smoother airflow and sound level reduction
- Charged for 15 feet of line set

WARRANTY

10 year limited warranty on compressor

10 year limited warranty on all parts, extended warranty available*

**Warranty provides for a total of 10 years of limited warranty coverage (Standard 5-year limited parts warranty plus an additional 5-year limited extended parts warranty). Warranty must be registered online within 60 days of installation to qualify for 10-year coverage. Unregistered equipment defaults to 5-year coverage. Lifetime limited heat exchanger warranty applies to registered equipment only (Standard 20 years with no online registration). See full warranty at www.alliedair.com for terms, conditions and exclusions.*

NOTE:

For the latest ratings, please see www.alliedratings.com or www.AHRInet.org



MODEL NUMBER GUIDE

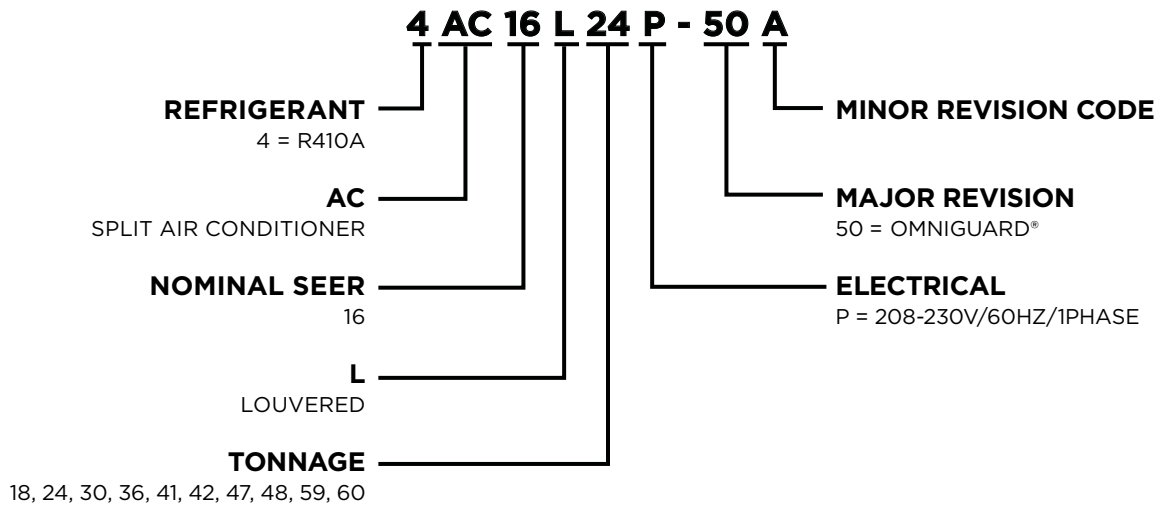

PHYSICAL AND ELECTRICAL DATA

Model	Voltage/Hz/Phase	Voltage Range	Min. Circuit Amp.	Max. Over Current Device (amps)	Compressor		Outdoor Fan Motor		Shipping Weight (lbs.)
					Rated Load (amps)	Locked Rotor (amps)	Rated Load (amps)	Rated HP	
4AC16L18P-50A	208-230/60/1	197-253	11.9	20	9	48	0.7	1/10	134
4AC16L24P-50A	208-230/60/1	197-253	14.6	25	10.9	59	1	1/6	152
4AC16L30P-50A	208-230/60/1	197-253	17	25	12.8	68	1	1/6	169
4AC16L36P-50A	208-230/60/1	197-253	18	30	13.6	79	1	1/6	181
4AC16L41P-50A	208-230/60/1	197-253	19.3	30	14.7	75	1	1/6	192
4AC16L42P-50A	208-230/60/1	197-253	23.4	40	17.9	112	1	1/6	211
4AC16L47P-50A	208-230/60/1	197-253	21.9	35	16.1	106	1.8	1/3	231
4AC16L48P-50A	208-230/60/1	197-253	24.2	40	18	117	1.7	1/4	218
4AC16L59P-50A	208-230/60/1	197-253	28.2	45	20.8	127	2.8	1/3	253
4AC16L60P-50A	208-230/60/1	197-253	29.6	50	22.2	128	1.8	1/3	226

Note:
Weights listed are unit weights with packaging
+ Factory charged for 15 feet of line set. Adjust per installation instructions.

UNIT DIMENSIONS & SOUND RATINGS

Model	Dimensions (inch)			Shipping Weight (Lbs.)	Sound Rating (dBA)
	A - Width	B - Depth	C - Height		
4AC16L18P-50A	24.25	24.25	29	155	73
4AC16L24P-50A	28.25	28.25	37	171	76
4AC16L30P-50A	28.25	28.25	37	187	76
4AC16L36P-50A	28.25	28.25	37	205	76
4AC16L41P-50A	28.25	28.25	37	227	74
4AC16L42P-50A	28.25	28.25	37	234	76
4AC16L47P-50A	32.25	32.25	43	272	80
4AC16L48P-50A	28.25	28.25	37	255	78
4AC16L59P-50A	32.25	32.25	43	284	77
4AC16L60P-50A	32.25	32.25	43	284	80

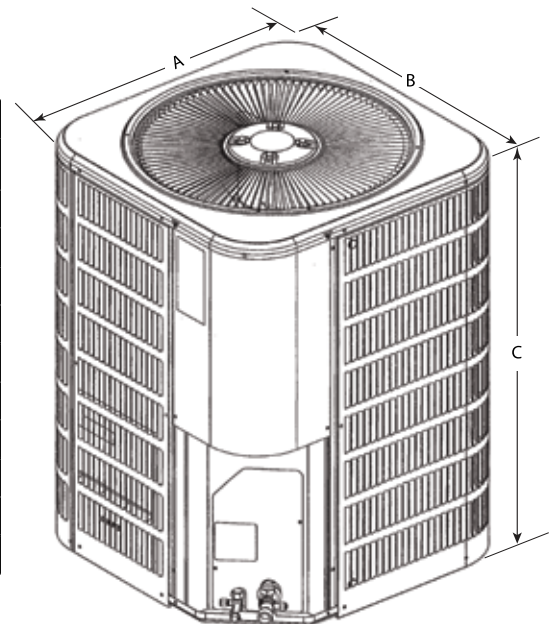

Note:
Dimensions listed are unit sizes w/o packaging

ACCESSORIES

Description	Where Used	Kit Number
Crankcase Heater	All Models	93M04
Hard Start Kit	18	10J42
	24, 30, 36, 41, 42, 47, 48, 59, 60	88M91
Low Ambient Kit	All Models	34M72
Short Cycle Protector	All Models	47J27
Freezestat	3/8 Tubing	93G35
Time Delay Relay	All Models	58M81
Loss Of Charge Kit	All Models	84M23 (Factory Installed)
Sound Blanket	18, 24, 30, 36, 41	14W00 (Factory Installed)
	42, 47, 48, 59, 60	14W01 (Factory Installed)
TXV Kit	18, 24, 30	H4TXV01
	36, 41, 42, 47, 48	H4TXV02
	59, 60	H4TXV03

REFRIGERATION DATA

Model	Refrig. Charge (oz.) *	TXV	Refrigerant Line Size		Outdoor Unit Connection		Indoor Unit Connection	
			Suction	Liquid	Suction	Liquid	Suction	Liquid
4AC14B18P-50	73	H4TXV01	3/4	3/8	3/4	3/8	3/4	3/8
4AC14B24P-50	73	H4TXV01	3/4	3/8	3/4	3/8	3/4	3/8
4AC14B30P-50	88	H4TXV01	3/4	3/8	3/4	3/8	3/4	3/8
4AC14B36P-50	113	H4TXV02	7/8	3/8	7/8	3/8	7/8	3/8
4AC14B41P-50	144	H4TXV02	7/8	3/8	7/8	3/8	7/8	3/8
4AC14B42P-50	140	H4TXV02	7/8	3/8	7/8	3/8	7/8	3/8
4AC14B47P-50	176	H4TXV02	7/8	3/8	7/8	3/8	7/8	3/8
4AC14B48P-50	156	H4TXV02	7/8	3/8	7/8	3/8	7/8	3/8
4AC14B59P-50	189	H4TXV03	1 1/8	3/8	7/8 **	3/8	7/8	3/8
4AC14B60P-50	192	H4TXV03	1 1/8	3/8	7/8 **	3/8	7/8	3/8

*Factory charged for 15 feet of line set

** Adapter shipped with unit

COOLING PERFORMANCE

Outdoor Model	Indoor Model	Capacity (BTUH)	EER	SEER
4AC14B18P-50	EAC4X24B	18,000	12.20	14.00
4AC14B24P-50	EAC4X24B	23,200	12.20	14.25
4AC14B30P-50	EAC4X30B	28,000	12.20	14.25
4AC14B36P-50	EAC4X36B	34,000	12.20	14.50
4AC14B41P-50	EAC4X49C	37,000	12.50	15.10
4AC14B42P-50	EAC4X49C	41,000	12.20	14.25
4AC14B47P-50	EAC4X60C	46,000	12.50	14.50
4AC14B48P-50	EAC4X60C	46,000	11.70	14.25
4AC14B59P-50	EAC4X60C	57,000	12.20	14.25
4AC14B60P-50	EAC4X60C	57,500	11.70	14.00

NOTE:

For the latest AHRI system matches please visit www.alliedratings.com or www.AHRInet.org



1-800-448-5872

All specifications and illustrations subject to change without notice and without incurring obligations.