

PRPHP14

PRODUCT SPECIFICATIONS

14 SEER HEAT PUMP PACKAGED UNIT

FORM NO. PRPHP14-100 (05/2019)

REFRIGERANT SYSTEM

- Environmentally friendly R410A refrigerant
- Copper tubing with enhanced fin coils
- Internal service gauge ports
- Sleeved distributor tubes
- Antimicrobial Drain Pan
- High and Low Threaded pressure switches for system protection

CABINET CONSTRUCTION

- Rounded corners for safety and an attractive, clean appearance
- One piece base design for strength and stability
- Drain ports for condensate management and coil runoff
- Low profile, with compact footprint
- Insulation to minimize heat loss plus reduce sound
- Textured pre-painted steel cabinet finish
- Superior service access to components
- Louvered coil guard protection
- One piece “no leak” top design

BLOWER

- Insulated compartment to reduce sound
- Efficient constant torque motor for wide airflow range
- Slide out blower housing for easy service

CONTROLS

- Integrated control with L.E.D. self diagnostics
- Defrost control board with field selectable time intervals
- Built in short cycle protection to protect compressor
- Built in “quiet shift” operation during defrost on select models

INSTALLATION

- Horizontal or down discharge capable
- Utility connections on “right side”
- Tabbed duct flanges for simple duct connection

ACCESSORIES

- Hinged roofcurbs
- Lifting brackets
- Internal Filter Kits
- Electric strip heat with optional single point power entry

WARRANTY

10 year limited parts and compressor warranty. See limited warranty document for details.



MODEL NUMBER GUIDE

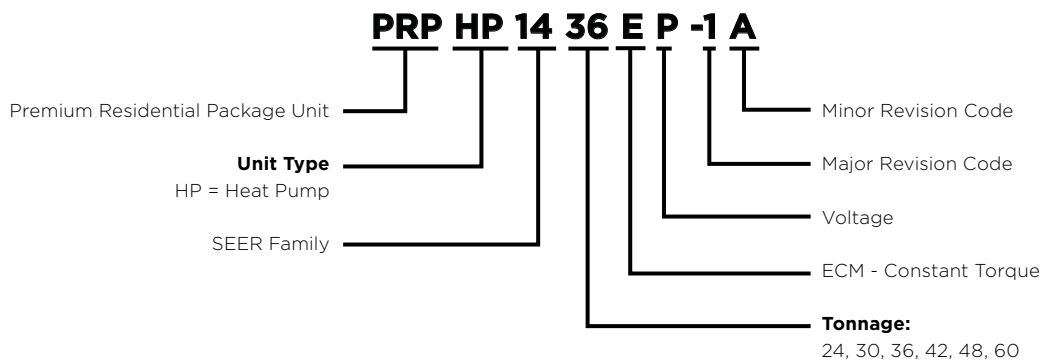

ELECTRICAL AND PHYSICAL DATA

Model	Voltage	Phase	Hz	Min Volts @ 60 hz	MCA	Max Fuse/HACR Breaker	Compressor		Condenser Motor		Blower Motor		Refrig. Charge (oz.)	Weight (lbs.)
							RLA	LRA	RLA	HP	RLA	HP		
PRPHP1424	208-230	1	60	197	17.4	25	12.1	59.3	1.0	1/6	2.8	1/3	91	315
PRPHP1430					21.9	35	15	72.5			4.1		96	324
PRPHP1436					23.4	35	14.7	75			4.1	1/2	90	340
PRPHP1442					27.8	40	16	85	1.7	1/4	6	1/3	173	433
PRPHP1448					28.7	45	16.9	94				1/2	173	438
PRPHP1460					39.7	60	27.1	144.2			7.6	1.0	161	460

PERFORMANCE

MODEL	COOLING					HEATING					Sound dBA
	Rated AHRI Capacity Btuh	SEER	EER	Rated Sensible Capacity Btuh	CFM	47 DEG.		HSPF	17 DEG.		
						BTUH	COP		BTUH	COP	
PRPHP1424	22,600	14.0	11.0	16,700	850	22,000	3.8	8.0	12,300	2.3	78
PRPHP1430	28,600		11.0	21,700	1050	27,000	3.7		15,900		
PRPHP1436	34,000		11.0	25,200	1250	32,400			20,000		76
PRPHP1442	40,000		11.0	30,800	1400	39,000	3.6		23,600	78	
PRPHP1448	46,000		11.0	34,000	1600	45,000	3.7		27,000	79	
PRPHP1460	57,000		11.0	41,600	1800	56,000			33,600	2.4	78

*Certified in accordance with Unitary Air Conditioner Certification Program, which is based on AHRI Standard 210/240

BLOWER PERFORMANCE

Model	Blower Tap	CFM @ ext. Static Pressure in in. wc without filter, dry coil									
		0.1	0.2	0.3	0.4	0.5	0.6	0.7	0.8	0.9	1.0
PRPHP1424	TAP 1	680	590	550	450	380	N/A	N/A	N/A	N/A	N/A
	TAP 2	890	830	800	760	710	680	640	600	N/A	N/A
	TAP 3	1000	960	930	880	840	810	770	730	N/A	N/A
PRPHP1430	TAP 1	680	640	600	570	530	490	N/A	N/A	N/A	N/A
	TAP 2	1100	1070	1050	1020	990	960	930	900	N/A	N/A
	TAP 3	1180	1160	1130	1090	1070	1040	1010	960	N/A	N/A
PRPHP1436	TAP 1	860	810	760	710	640	590	550	490	N/A	N/A
	TAP 2	1300	1265	1235	1200	1165	1125	1085	1040	1000	885
	TAP 3	1475	1450	1420	1375	1345	1310	1275	1190	1070	885
PRPHP1442	TAP 1	800	720	640	550	475	390	310	0	0	0
	TAP 2	1470	1410	1360	1300	1260	1210	1155	1095	1000	940
	TAP 3	1700	1650	1610	1575	1540	1480	1430	1390	1340	1210
PRPHP1448	TAP 1	1145	1075	1000	930	850	790	740	670	570	490
	TAP 2	1675	1630	1600	1540	1490	1440	1390	1300	1230	1125
	TAP 3	1800	1770	1715	1690	1640	1610	1565	1500	1460	1380
PRPHP1460	TAP 1	1400	1320	1260	1200	1120	1060	980	900	N/A	N/A
	TAP 2	1920	1870	1820	1770	1720	1670	1450	1360	N/A	N/A
	TAP 3	2235	2195	2165	2130	2090	2060	2025	1985	1960	1940

COOLING PERFORMANCE - EXTENDED RATINGS

Outdoor Model	Indoor Temp DB/ WB °F	Outdoor Temperature - DB °F														
		65°			82°			95°			105°			115°		
		Btuh	S/T	kW	Btuh	S/T	kW	Btuh	S/T	kW	Btuh	S/T	kW	Btuh	S/T	kW
PRPHP1424	85 / 72	29500	0.63	1.4	28100	0.65	1.67	27000	0.67	1.89	25400	0.72	2.06	23800	0.78	2.23
	80 / 67	27800	0.70	1.39	26300	0.72	1.65	24800	0.74	1.89	23300	0.80	2.07	21800	0.86	2.24
	75 / 63	26400	0.73	1.38	24400	0.76	1.66	22800	0.79	1.87	21500	0.84	2.06	20300	0.88	2.25
	75 / 57	23300	1.00	1.38	21800	1.00	1.65	20600	1.00	1.86	20100	1.00	2.05	19500	1.00	2.25
PRPHP1430	85 / 72	29700	0.66	1.92	31300	0.69	2.27	32600	0.71	2.53	29600	0.74	2.71	26600	0.76	2.89
	80 / 67	33500	0.71	1.89	32700	0.74	2.18	30100	0.76	2.48	27900	0.80	2.69	25600	0.84	2.9
	75 / 63	31700	0.75	1.85	29200	0.79	2.21	27400	0.82	2.49	25600	0.84	2.69	23800	0.86	2.89
	75 / 57	29900	1.00	1.87	27500	1.00	2.24	25800	1.00	2.52	24500	1.00	2.71	23300	1.00	2.89
PRPHP1436	85 / 72	44500	0.70	2.25	40600	0.74	2.6	37400	0.78	2.91	35000	0.80	3.19	32600	0.84	3.49
	80 / 67	41100	0.77	2.24	37600	0.81	2.58	34400	0.79	2.9	32300	0.87	3.17	30100	0.92	3.48
	75 / 63	38500	0.79	2.22	35100	0.83	2.57	32200	0.87	2.87	30200	0.90	3.15	28100	0.93	3.46
	75 / 57	36000	1.00	2.21	33300	1.00	2.56	31000	1.00	2.9	29300	1.00	3.15	27500	1.00	3.46
PRPHP1442	85 / 72	52600	0.69	2.5	48100	0.72	2.91	44100	0.75	3.3	41400	0.77	3.66	36900	0.76	4.03
	80 / 67	48200	0.75	2.51	44200	0.79	2.91	40500	0.78	3.27	37800	0.84	3.67	35000	0.90	4.04
	75 / 63	45100	0.78	2.51	41200	0.81	2.92	38100	0.85	3.31	35500	0.87	3.68	32600	0.92	4.04
	75 / 57	42000	1.00	2.52	38800	1.00	2.92	36100	1.00	3.32	34200	1.00	3.68	31700	1.00	4.05
PRPHP1448	85 / 72	59300	0.69	2.76	54400	0.72	3.29	50200	0.75	3.72	46800	0.78	4.05	43300	0.82	4.42
	80 / 67	54800	0.76	2.78	50100	0.79	3.28	46500	0.79	3.68	43300	0.85	4.04	40100	0.89	4.4
	75 / 63	51200	0.78	2.78	46800	0.81	3.27	43400	0.84	3.69	40400	0.87	4.02	37600	0.91	4.38
	75 / 57	47700	1.00	2.79	44200	1.00	3.26	41400	1.00	3.68	39000	1.00	4.01	36500	1.00	4.37
PRPHP1460	85 / 72	74100	0.62	3.54	68100	0.65	4.32	63500	0.67	4.91	60100	0.71	5.53	56600	0.75	6.14
	80 / 67	69200	0.69	3.51	63000	0.71	4.24	57400	0.73	4.85	55000	0.78	5.48	52400	0.82	6.1
	75 / 63	64200	0.72	3.49	57100	0.74	4.19	51700	0.76	4.72	50400	0.80	5.39	49000	0.84	6.07
		57500	1.00	3.44	51700	1.00	4.21	47300	1.00	4.8	46900	1.00	5.42	46500	1.00	6.04

HEAT STRIP ELECTRICAL

Model Number	Heater Model	Unit Supply Voltage Single Phase	Heater kW	Min. Circuit Ampacity 1	Max. Fuse / HACR Brkr. 1	Min. Circuit Ampacity 2	Max. Fuse / HACR Brkr. 2	Min. Circuit Ampacity Single Point	Max. Fuse / HACR Brkr. Single Point
PRPHP1424	PHK05BP-1	240	5	28.8	30	-	-	42.4	45
		208	3.8	25.4	30	-	-	39.1	45
	PHK07BP-1	240	7.5	41.9	45	-	-	55.6	60
		208	5.6	36.7	40	-	-	50.3	60
	PHK10BP-1	240	10	54.9	60	-	-	68.6	70
		208	7.5	47.9	50	-	-	61.6	70
PRPHP1430	PHK05BP-1	240	5	28.8	30	-	-	45.7	50
		208	3.8	25.4	30	-	-	42.3	45
	PHK07BP-1	240	7.5	41.9	45	-	-	58.8	60
		208	5.6	36.7	40	-	-	53.6	60
	PHK10BP-1	240	10	54.9	60	-	-	71.8	80
		208	7.5	47.9	50	-	-	64.8	70
	PHK15CP-1	240	15	54.9	60	26	30	97.8	100
		208	11.3	47.9	50	22.6	25	87.4	90
PRPHP1436	PHK05BP-1	240	5	31.2	35	-	-	49.5	50
		208	3.8	27.7	30	-	-	46	50
	PHK07BP-1	240	7.5	44.2	45	-	-	62.5	70
		208	5.6	39	40	-	-	57.3	60
	PHK10BP-1	240	10	57.2	60	-	-	75.5	80
		208	7.5	50.3	55	-	-	68.6	70
	PHK15CP-1	240	15	57.2	60	26	30	101.5	110
		208	11.3	50.2	50	22.6	25	91.1	100
PRPHP1442	PHK05BP-1	240	5	33.5	35	-	-	53.8	60
		208	3.8	30.1	35	-	-	50.3	60
	PHK07BP-1	240	7.5	46.6	50	-	-	66.8	70
		208	5.6	41.4	45	-	-	61.6	70
	PHK10BP-1	240	10	59.6	60	-	-	79.9	80
		208	7.5	52.6	55	-	-	72.9	80
	PHK15CP-1	240	15	59.6	60	26	30	105.9	110
		208	11.3	52.6	55	22.6	25	95.5	100
PHK20CP-1	240	20	59.6	60	52.1	60	131.9	150	
	208	15	52.6	60	45.1	50	118	125	
PRPHP1448	PHK05BP-1	240	5	33.5	35	-	-	54.8	60
		208	3.8	30.1	35	-	-	51.3	60
	PHK07BP-1	240	7.5	46.6	50	-	-	67.8	70
		208	5.6	41.4	45	-	-	62.6	70
	PHK10BP-1	240	10	59.6	60	-	-	80.8	90
		208	7.5	52.6	55	-	-	73.9	80
	PHK15CP-1	240	15	59.6	60	26	30	106.9	110
		208	11.3	52.6	55	22.6	25	96.4	100
	PHK20CP-1	240	20	59.6	60	52.1	60	132.9	150
		208	15	52.6	60	45.1	50	119	125

MODEL NO.	HEATER MODEL	Unit Supply Voltage Single Phase	Heater kW	Min. Circuit Ampacity 1	Max. Fuse / HACR Brkr. 1	Min. Circuit Ampacity 2	Max. Fuse / HACR Brkr. 2	Min. Circuit Ampacity Single Point	Max. Fuse / HACR Brkr. Single Point
PRPHP1460	PHK05BP-1	240	5	33.6	35	-	-	64	80
		208	3.8	30.2	35	-	-	60.6	80
	PHK07BP-1	240	7.5	46.7	50	-	-	77.1	90
		208	5.6	41.5	45	-	-	71.9	80
	PHK10BP-1	240	10	59.7	60	-	-	90.1	100
		208	7.5	52.7	60	-	-	83.1	90
	PHK15BP-1	240	15	59.7	60	26	30	116.1	125
		208	11.3	52.7	60	22.6	25	105.7	110
PHK20BP-1	240	20	59.7	60	52.1	60	142.1	150	
	208	15	52.7	60	45.1	50	128.2	150	

HEATING PERFORMANCE EXT. RATINGS

Model	Outdoor Temp. DB/WB deg. F									
	0/0		17/15		35/33		47/43		62/56	
	Btuh	KW	Btuh	KW	Btuh	KW	Btuh	KW	Btuh	KW
PRPHP1424	7000	1.55	12300	1.60	17900	1.68	22000	1.71	27800	1.75
PRPHP1430	9900	1.92	15900	2.00	22200	2.10	27300	2.16	33000	2.23
PRPHP1436	19000	2.10	23800	2.40	28900	2.72	32300	2.93	36600	3.2
PRPHP1442	13600	2.88	23500	3.03	33900	3.19	40900	3.29	49600	3.42
PRPHP1448	15300	3.18	26300	3.35	57900	3.56	45700	3.66	55400	3.82
PRPHP1460	20100	3.89	33700	4.10	48100	4.51	57000	4.78	67400	4.88

DIMENSIONS (IN.)

Model	A		B		C		D		E		F		G		H	
	in.	mm	in.	mm	in.	mm	in.	mm	in.	mm	in.	mm	in.	mm	in.	mm
PRPHP1424	36-7/8	937	46-3/4	1187	13-3/8	340	5-7/8	149	16-3/4	425	14	356	30-1/8	762	25-1/2	648
PRPHP1430																
PRPHP1436																
PRPHP1442	40-7/8	1038	55-1/4	1403	18-1/8	467	4-5/8	117	19-3/4	502	19-1/2	495	34-1/8	864	29-1/2	749
PRPHP1448																
PRPHP1460																

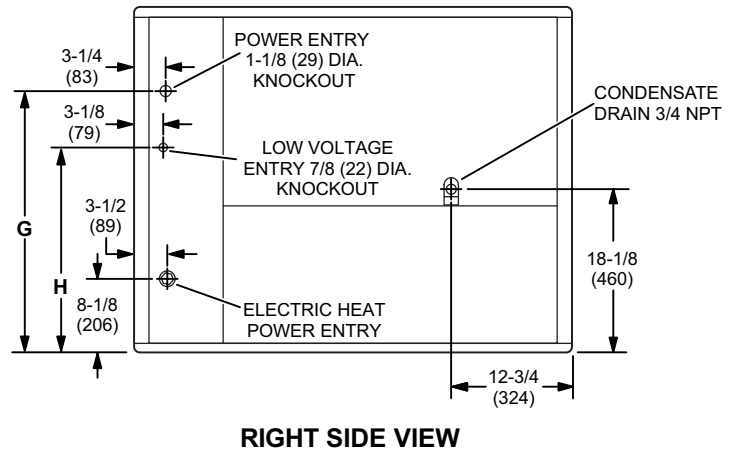
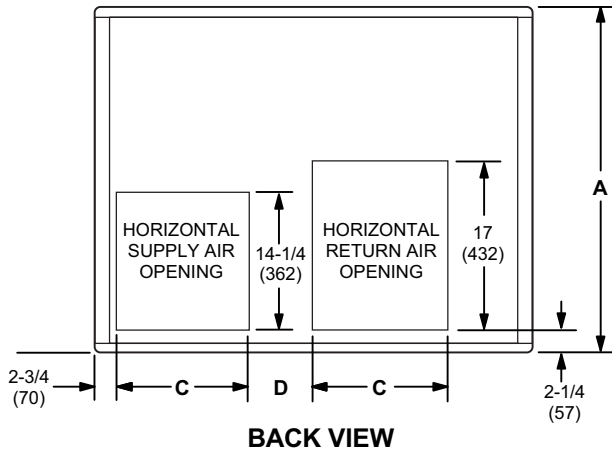
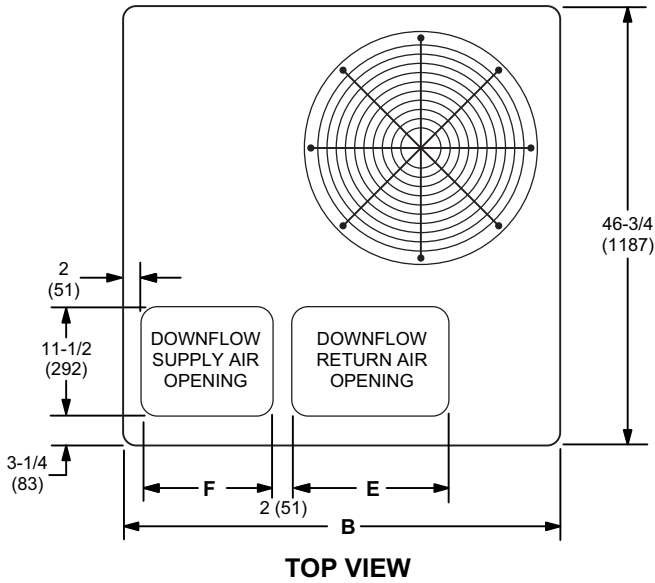

ROOF CURB DIMENSIONS

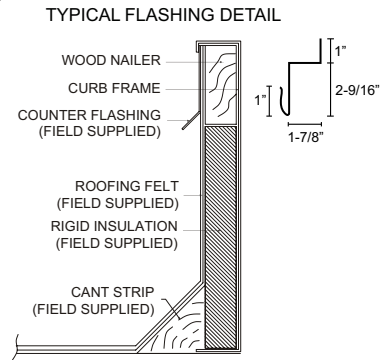
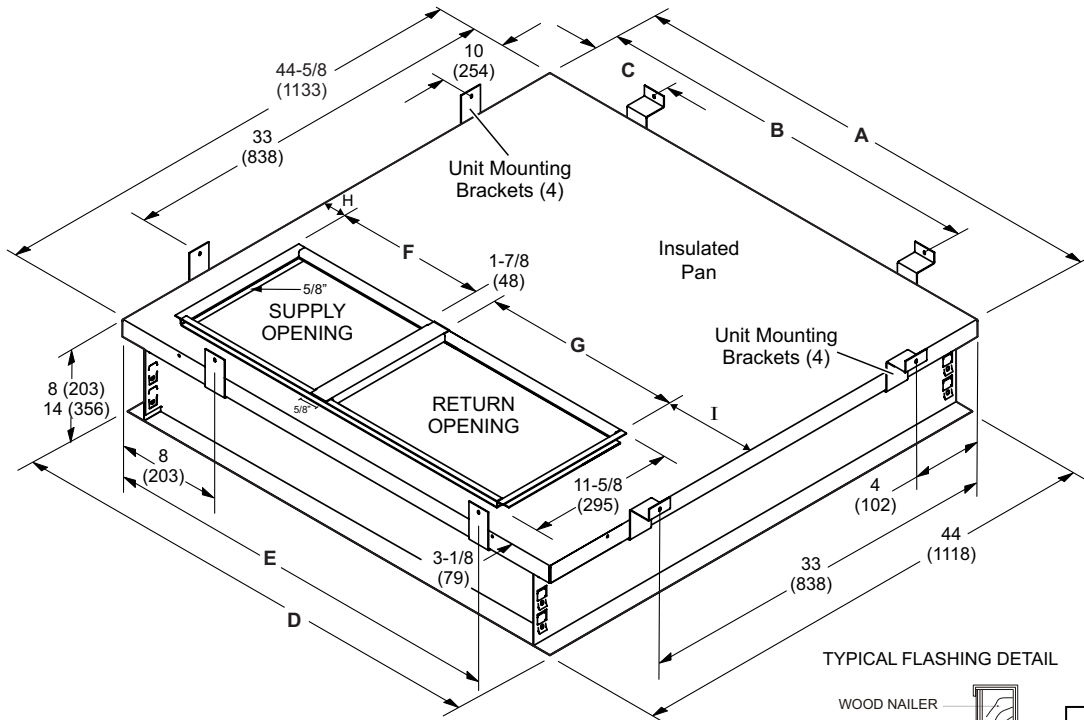

Usage	A		B		C		D		E	
	in.	mm	in.	mm	in.	mm	in.	mm	in.	mm
24, 36	44-5/8	1133	43	1092	18	457	44	1118	37	940
48, 60	53-1/8	1349	51	1295	24	610	52-1/2	1334	41	1041
Usage	F		G		H		I			
	in.	mm	in.	mm	in.	mm	in.	mm		
24, 36	14	356	16-3/4	425	2	51	9-3/4	248		
48, 60	19-1/2	495	19-3/4	502	2	51	10	254		

ACCESSORIES

Description	Where Used	Kit Number
Compressor Crankcase Heater	36, 42, 48, 60	11X27
Compressor Hard Start Kit	36, 60	10J42
Compressor Hard Start Kit	42, 48	88M91
Compressor Timed-Off Control	All	47J27
Down Flow Conversion - ACONVR836	24, 30, 36	1.851401
Down Flow Conversion - ACONVR837	42, 48, 60	1.851402
Drain pan overflow switch	All	11U75
Electric Heater 5KW - PHK05BP	All	10W47
Electric Heater 7.5KW - PHK07BP	All	10W48
Electric Heater 10KW - PHK10BP	All	10W49
Electric Heater 15KW - PHK15CP	30, 36, 42, 48, 60	10W50
Electric Heater 20KW - PHK20CP	42, 48, 60	10W51
Filter Rack Kit	24, 30, 36	11U73
Filter Rack Kit	42, 48, 60	11U74
Lifting Brackets	All	11U76
Sideflow Rect. to 14" Rounds Duct Adapter (Qty 25 sets)	24, 30, 36	R104617-01
	42, 48, 60	R104618-01
8" Height Full Perimeter Curb	24, 30, 36	14W71
8" Height Full Perimeter Curb	42, 48, 60	14W72
14" Height Full Perimeter Curb	24, 30, 36	14V68
14" Height Full Perimeter Curb	42, 48, 60	14V69

Single Point Power		
5 KW ASPWR813-1	All	13W88
7.5 KW ASPWR814-1	All	13W89
10 KW ASPWR815-1	All	13W90
15-20 KW ASPWR816-1	30, 36, 42, 48, 60	13W91



1-800-448-5872

All specifications and illustrations subject to change without notice and without incurring obligations.